

21+ / FORD BRONCO

FRAME HORN GUSSET

AC2303701NA

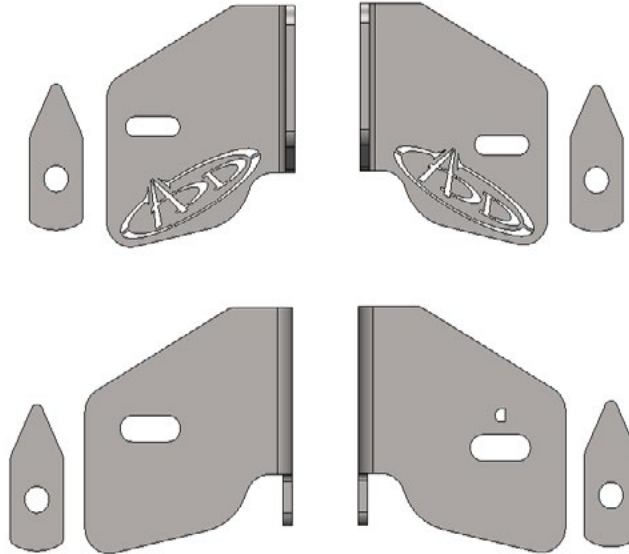

TOOLS REQUIRED

(Wrench) 15mm, 9/16, 3/4
(Socket) 15mm, 9/16, 3/4
Ratchet



TIME REQUIRED

- 1 hours for OEM Removal/Gusset Install



SKILL LEVEL

-Easy/Intermediate



INCLUDED IN KIT

- 2- 1/2-13 x 1 1/4" Hex Head Bolt - Grade 8
- 2- 1/2-13" Metal Lock Nuts - Grade C
- 4- 1/2" Flat Washer - Zinc
- 2- 3/8-16 x 1" Hex Head Bolt - Grade 8
- 2- 3/8-16" Metal Lock Nuts - Grade C
- 4- 3/8" Flat Washer - Zinc

⚠️ WARNINGS/CAUTIONS BEFORE STARTING INSTALLATION ⚠️

-BEFORE YOU INSTALL THIS KIT-

Read and understand all instructions, warnings, cautions, & notes contained in this installation instruction guide. Consult your vehicle owner's manual for proper disconnection of electrical and lifting of vehicle if required for installation of this product.

This install may require some technical skills and knowledge of basic mechanical work. If you do not feel that you are capable of performing this install please take this product to a trained professional.

After reading this guide please contact us with any questions or concerns before installing product.
Customer Service (480) 671-0820

Addictive desert designs is *not* responsible for any bodily injury or harm to you or your vehicle as a result of an improper install.

Proper installation of this kit required knowledge of the factory recommended procedures for removal and installation of original equipment components.

We recommend that the factory shop manual and any special tools needed to service your vehicle be on hand during the installation. Installation of this kit without proper knowledge of the factory recommended procedures may affect the performance of these components and the safety of the vehicle.

Inspect all contents of this package to make sure product is not damaged and all installation hardware has been included. If parts are missing from kit, please be prepared to provide the following information:

1. Name of purchase location
2. Bar Code on side of box
3. Date above bar code
4. Date inside box cover

ALWAYS WEAR EYE PROTECTION WHEN OPERATING POWER TOOLS

HARDWARE/PARTS

A.

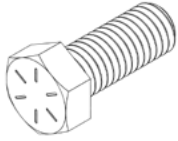

3/8-16 X 1" HEX HEAD GRADE 8

QTY: 2

A1.



3/8" FLAT WASHER ZINC

QTY: 4

A2.



3/8-16" LOCK NUT GRADE C

QTY: 2

B.

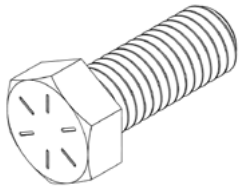

1/2-13 X 1-1/4" HEX HEAD GRADE 8

QTY: 2

B1.



1/2" FLAT WASHER ZINC

QTY: 4

B2.

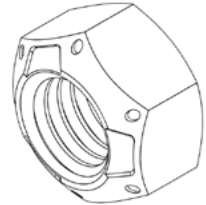

1/2-13" LOCK NUT GRADE C

QTY: 2

C.



SPACER

QTY: 4

Reference this page throughout the install

FRAME HORN GUSSET 21+/FORD BRONCO

REMOVAL

□ STEP 1

Remove the skid plate using a (15mm Socket). (Keep all of the OEM bolts for they will be used later in the install)

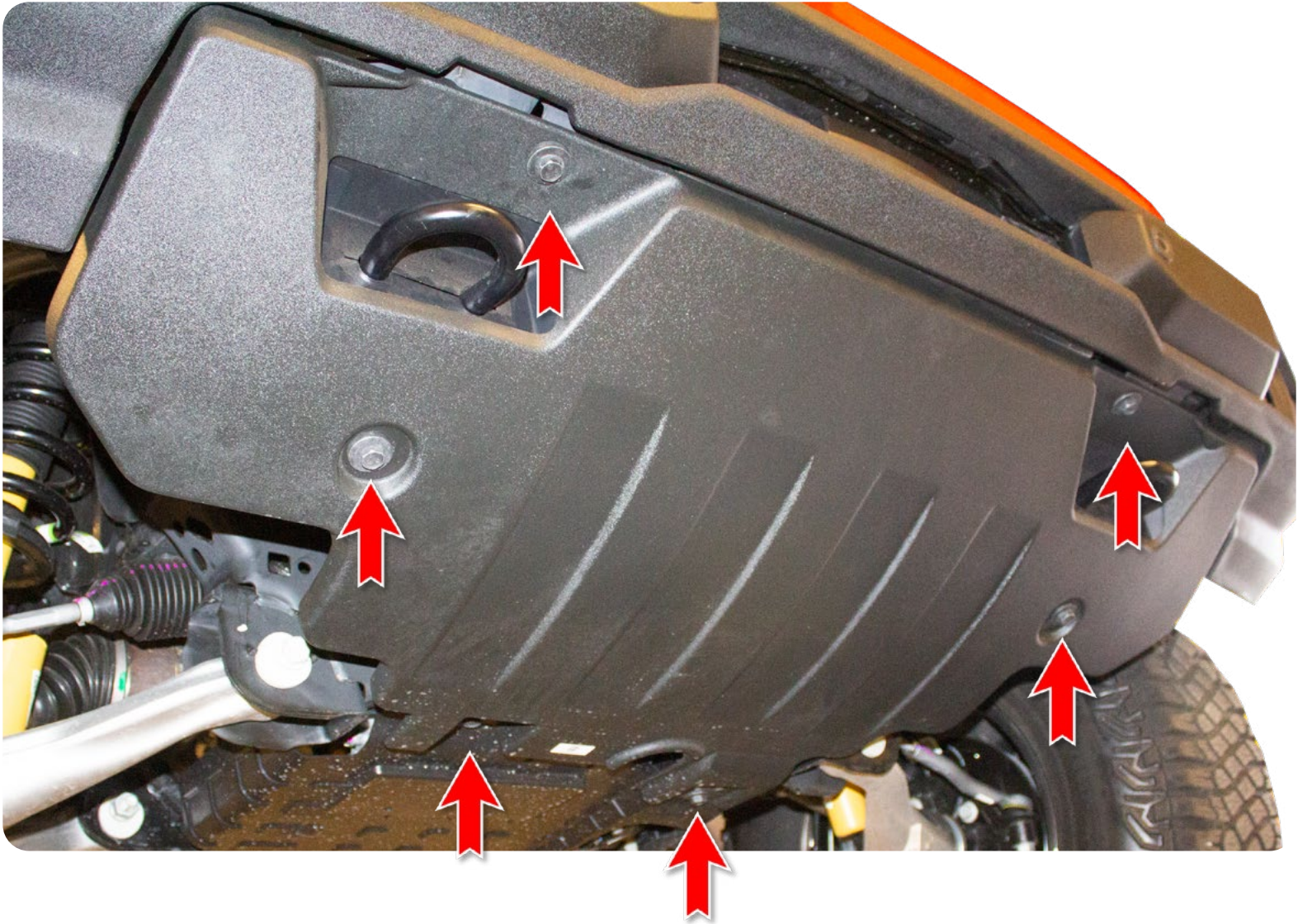

FRAME HORN GUSSET 21+/FORD BRONCO

REMOVAL

□ STEP 2

Disconnect the main wiring harness located on the driver side of the Bronco (Found next to the headlight, up in the corner)



PLASTIC BUMPER

FRAME HORN GUSSET
21+/FORD BRONCO

REMOVAL

□ STEP 3

Pull off the cover on each side of the bumper and unplug the sensors by spreading the sensor bezel tabs apart, which will release the tension and allow you to easily push back the sensors. (Make sure to keep track of the position/orientation of the parking sensors so that you can install them in the same position/orientation on your new bumper)

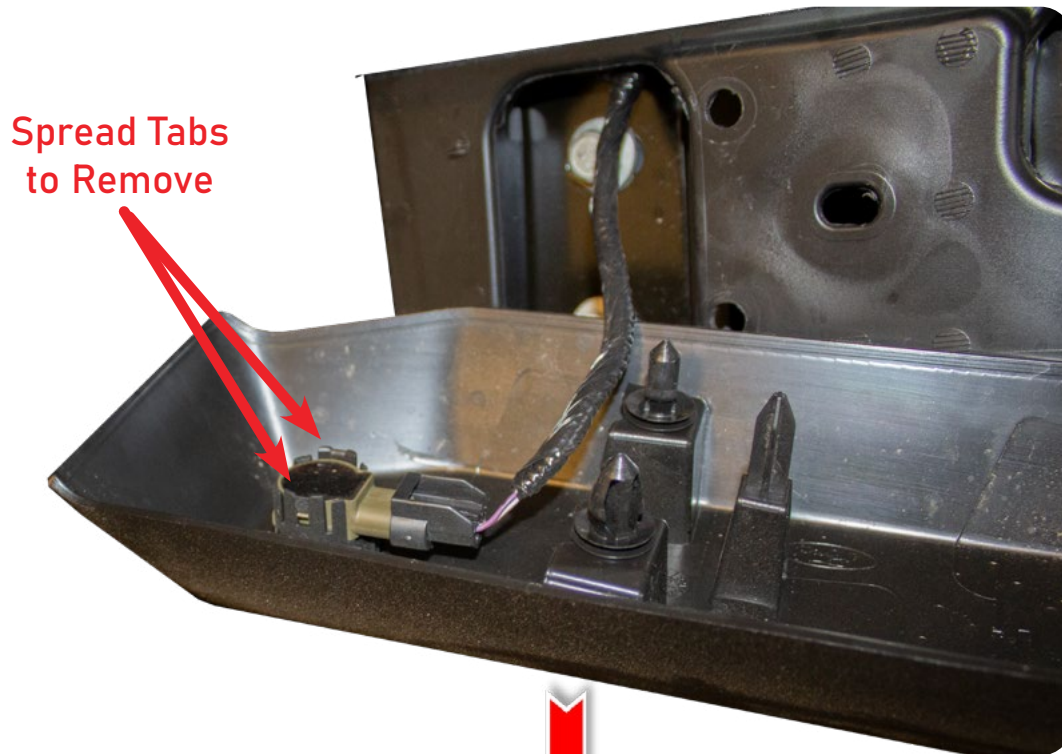

PLASTIC BUMPER

FRAME HORN GUSSET
21+/FORD BRONCO

REMOVAL

□ STEP 4

Remove plastic cover then unbolt the three bolts that hold the OEM bumper in place with a (15mm socket).

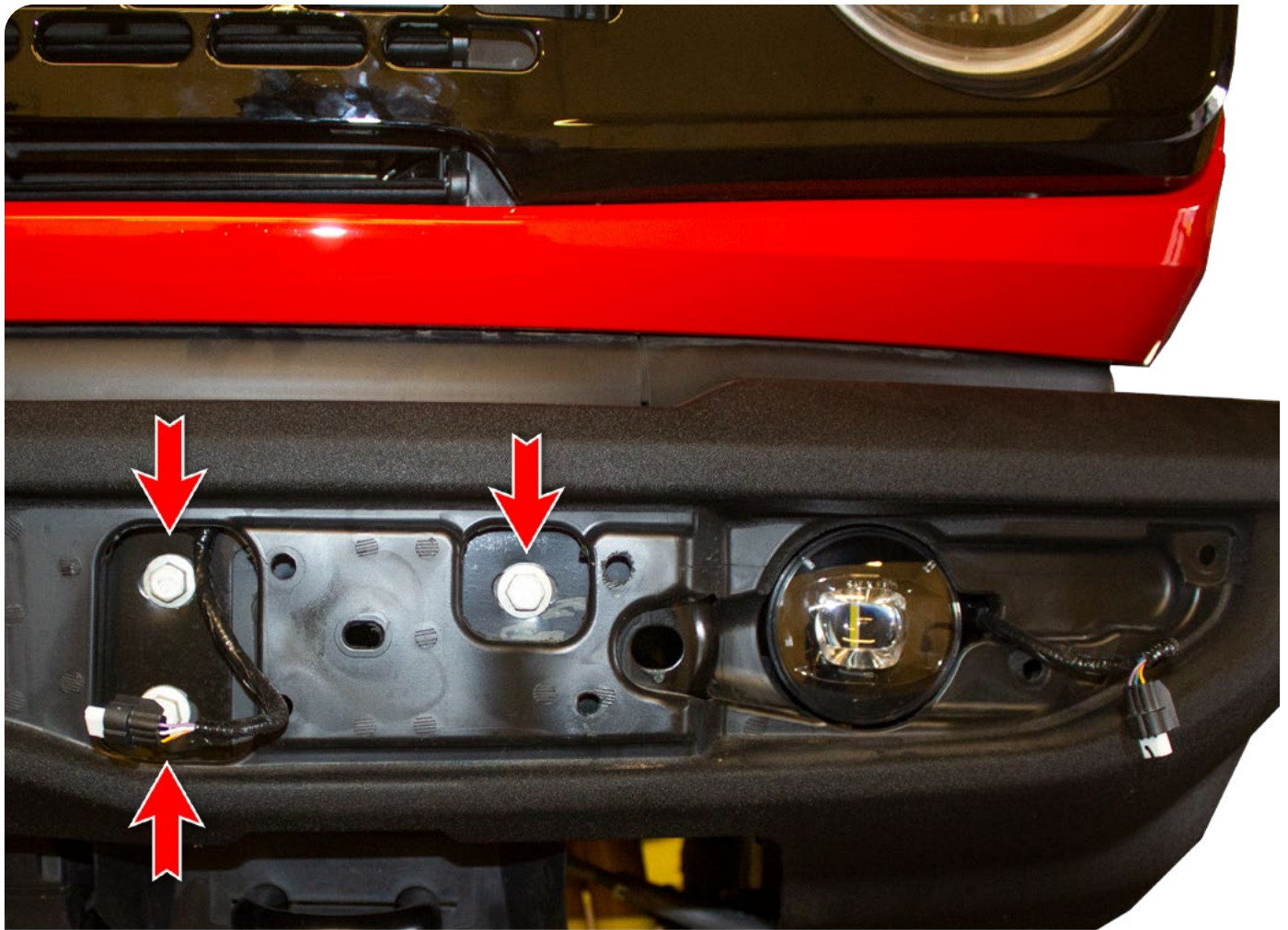

STEEL BUMPER

FRAME HORN GUSSET
21+/FORD BRONCO

REMOVAL

□ STEP 5

Remove the four plastic clips shown below on each side using a (fastener removal tool). Next remove the six bolts, three on each side using a (15mm socket).

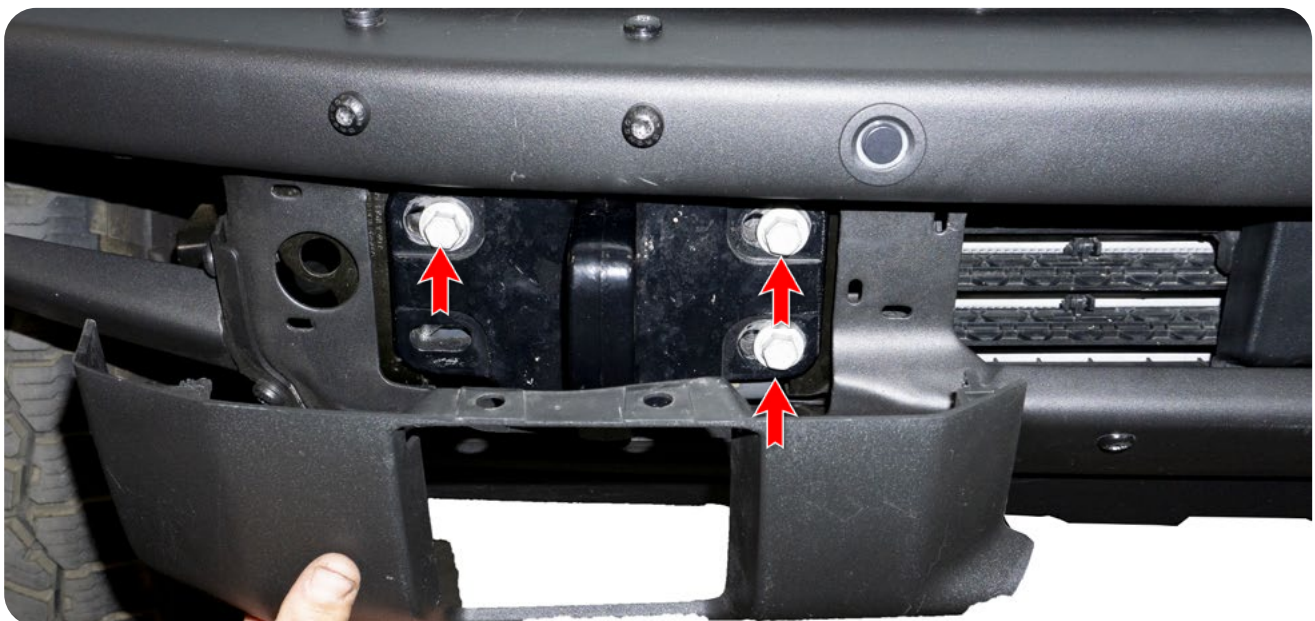

FRAME HORN GUSSET 21+/**FORD BRONCO**

REMOVAL

□ STEP 6

Remove the mounting bracket plastic nuts located behind the frame horns. There are 2x on each side.



FRAME HORN GUSSET 21+/FORD BRONCO

INSTALL

□ STEP 7

Install the brackets with the ADD logo on the outside on both driver and passenger with the provided hardware (**A, A1, A2**) and holding the spacer (**C**) upright as shown below.

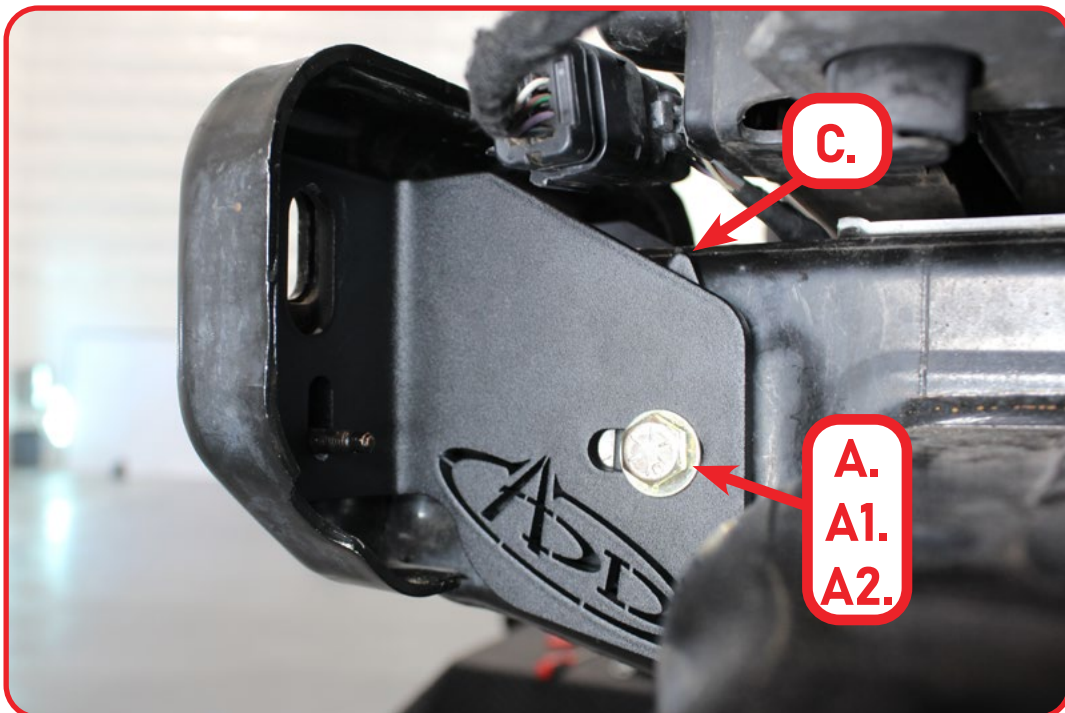
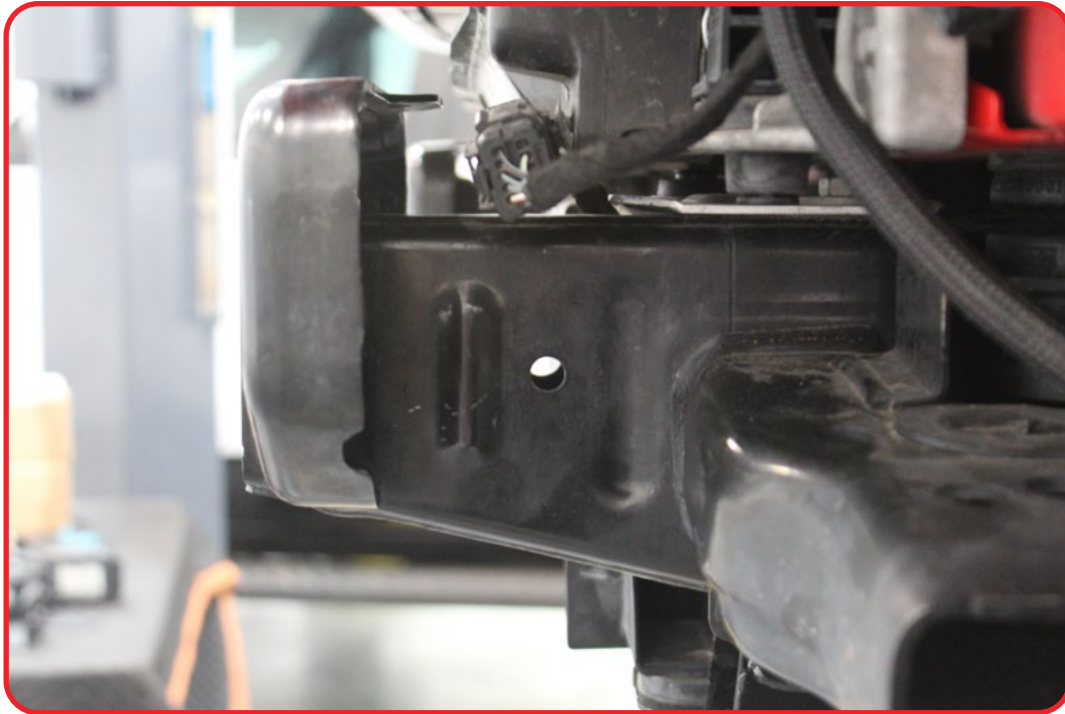

FRAME HORN GUSSET 21+/FORD BRONCO

INSTALL

□ STEP 8

Install the brackets with the marking D and P on the outside on both driver and passenger with the provided hardware (**B, B1, B2**) and holding the spacer (**C**) upright as shown below.

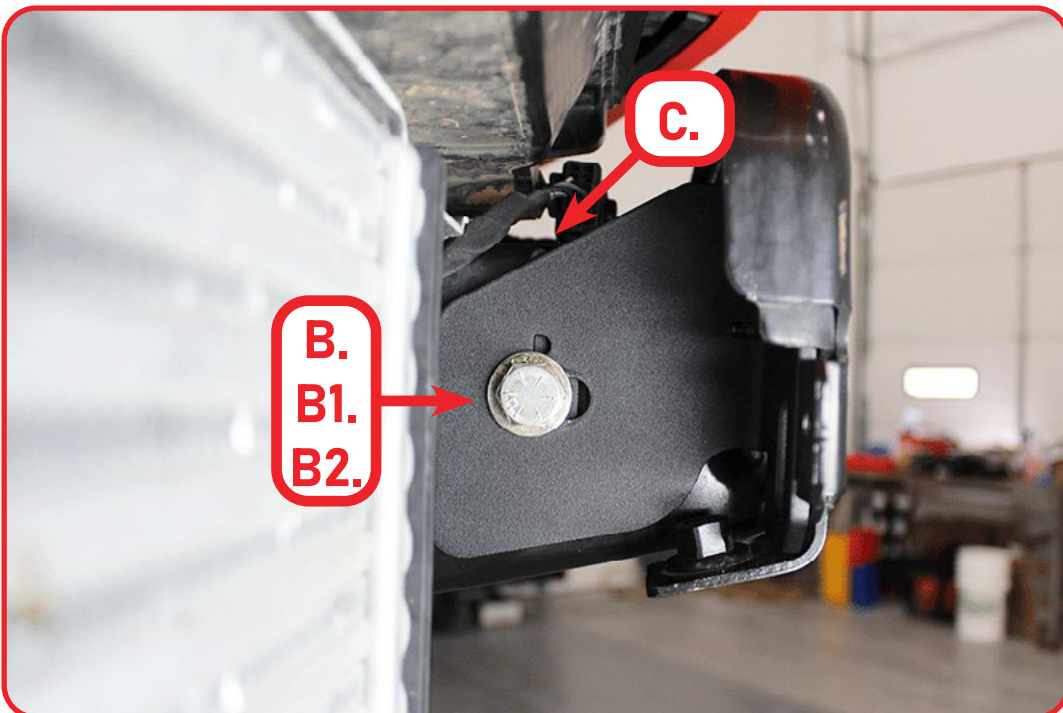

FRAME HORN GUSSET 21+/**FORD BRONCO**

INSTALL

□ STEP 9

Before tightening the inner gussets ensure to push the bracket against the frame horn while pushing up to align the slots with the frame horn holes and tighten using a (3/4 socket) and a (3/4 Wrench).

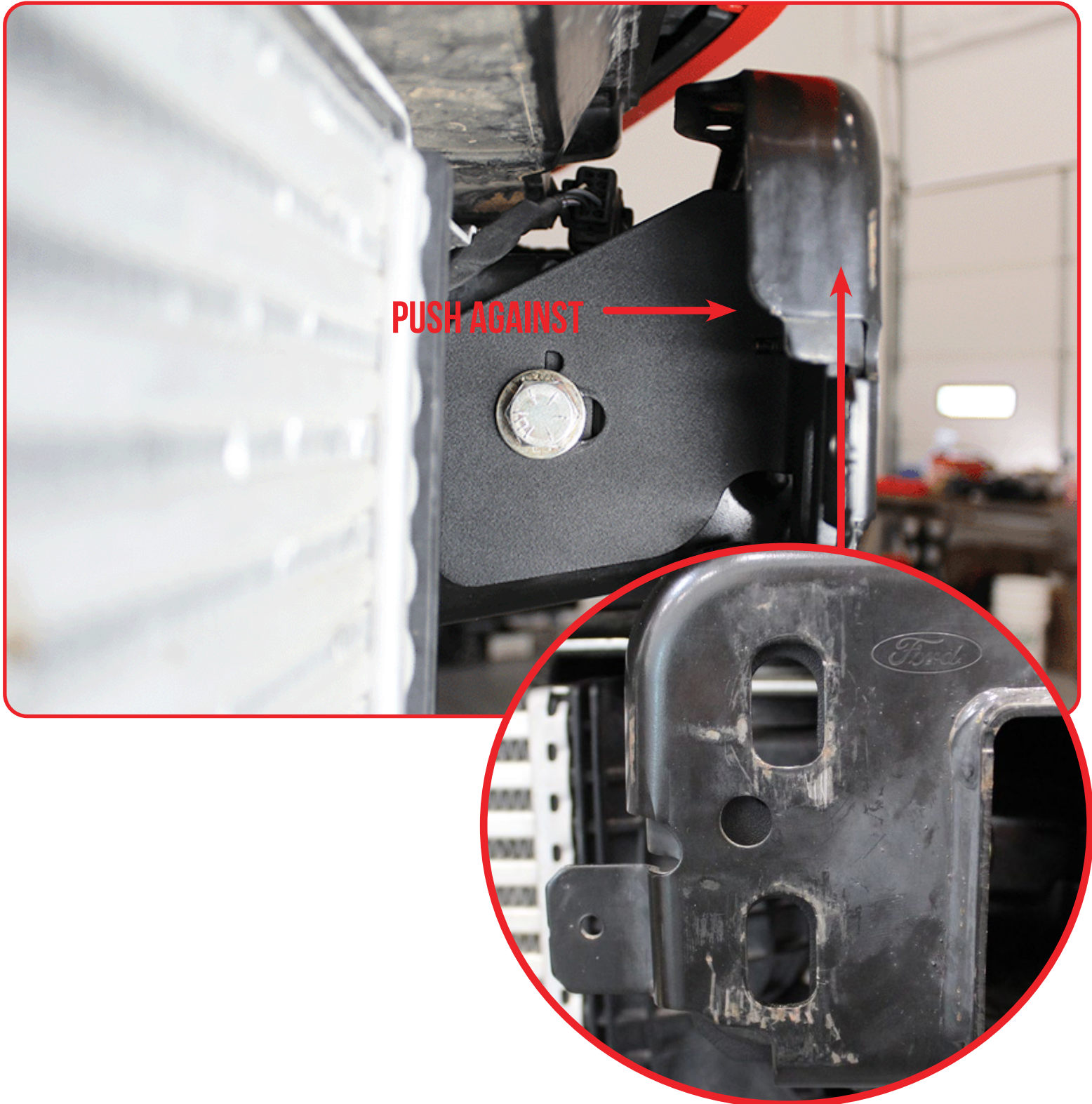

FRAME HORN GUSSET 21+/FORD BRONCO

INSTALL

□ STEP 10

Before tightening the outer gussets ensure to push the bracket against the frame horn while pushing up to align the holes with the frame horn and tighten using a (9/16 socket) and a (9/16 Wrench).



FRAME HORN GUSSET 21+/FORD BRONCO

FINAL

STEP 11

Stand back and enjoy your new ADD Frame Horn Gussets.

Check and re-tighten, if needed, all mounting bolts after 100 miles and periodically thereafter.



THIS PRODUCT IS PROTECTED BY ONE OR MORE U.S. PATENTS
WWW.ADDICTIVEDESERTDESIGNS.COM/PATENTS

FOR ADDITIONAL SUPPORT OR TECHNICAL QUESTIONS,
PLEASE CALL 480-671-0820 OR
EMAIL INFO@ADDICTIVEDESERTDESIGNS.COM