

23+ / FORD F-150

BED CHANNEL STIFFENER

AC1902501NA

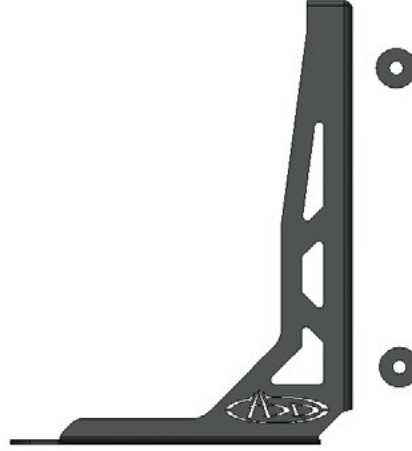
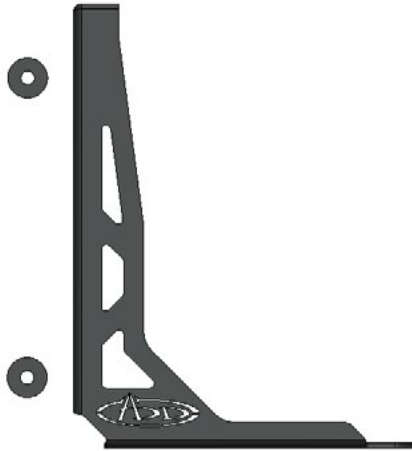

TOOLS REQUIRED

- (Socket) 8mm, 3/4
- (Wrench) 3/4
- (Torx) T50
- (Allen) 5/16
- (Drill Bit) 9/16
- Ratchet
- Drill



SKILL LEVEL

-Easy/Intermediate



TIME REQUIRED

- 1 hours for OEM Removal/Install



INCLUDED IN KIT

- 6- 1/2-13 X 1-1/2" Button Head Bolt
- 12- 1/2" Flat Washer
- 6- 1/2-13" Nylon Lock Nut
- 4- Bed Channel Stiffener Washers

⚠️ WARNINGS/CAUTIONS BEFORE STARTING INSTALLATION ⚠️

-BEFORE YOU INSTALL THIS KIT-

Read and understand all instructions, warnings, cautions, & notes contained in this installation instruction guide. Consult your vehicle owner's manual for proper disconnection of electrical and lifting of vehicle if required for installation of this product.

This install may require some technical skills and knowledge of basic mechanical work. If you do not feel that you are capable of performing this install please take this product to a trained professional.

After reading this guide please contact us with any questions or concerns before installing product.
Customer Service (480) 671-0820

Addictive desert designs is *not* responsible for any bodily injury or harm to you or your vehicle as a result of an improper install.

Proper installation of this kit required knowledge of the factory recommended procedures for removal and installation of original equipment components.

We recommend that the factory shop manual and any special tools needed to service your vehicle be on hand during the installation. Installation of this kit without proper knowledge of the factory recommended procedures may affect the performance of these components and the safety of the vehicle.

Inspect all contents of this package to make sure product is not damaged and all installation hardware has been included. If parts are missing from kit, please be prepared to provide the following information:

1. Name of purchase location
2. Bar Code on side of box
3. Date above bar code
4. Date inside box cover

ALWAYS WEAR EYE PROTECTION WHEN OPERATING POWER TOOLS

HARDWARE/PARTS

A.

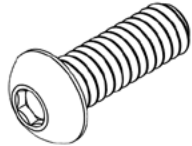

1/2-13 X 1-1/2" BUTTON HEAD BOLT

QTY: 6

A1.



1/2" FLAT WASHER

QTY: 12

A2.

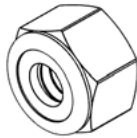

1/2-13" NYLON LOCK NUT

QTY: 6

B.



BED CHANNEL STIFFENER WASHER

QTY: 4

Reference this page throughout the install

BED CHANNEL STIFFENER 23+ / FORD F-150

REMOVAL

□ STEP 1

Remove the bed bolt using a (T50 Torx). (keep OEM bed bolts for they will be re-used later in the install)

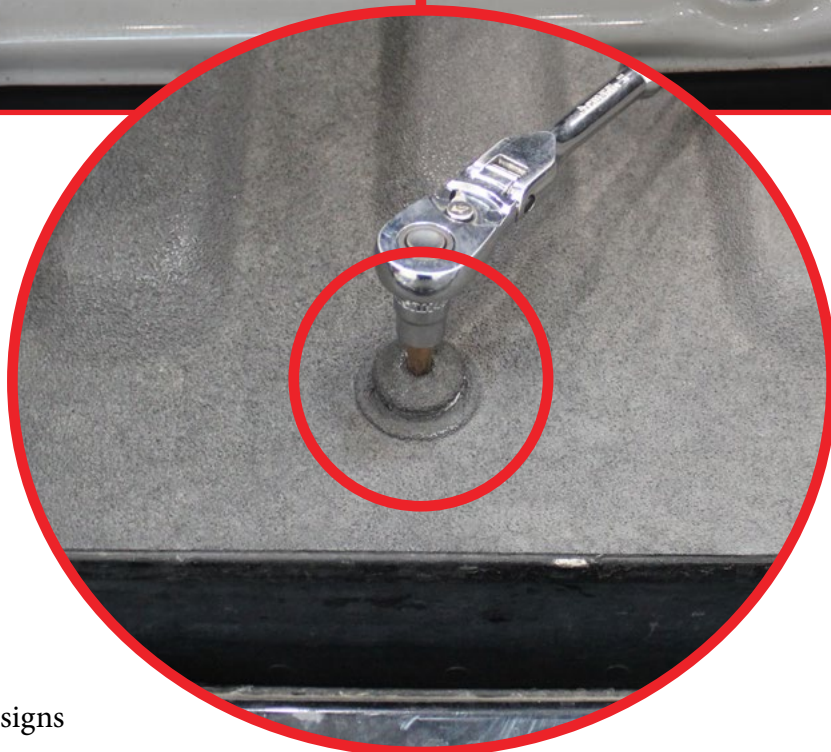
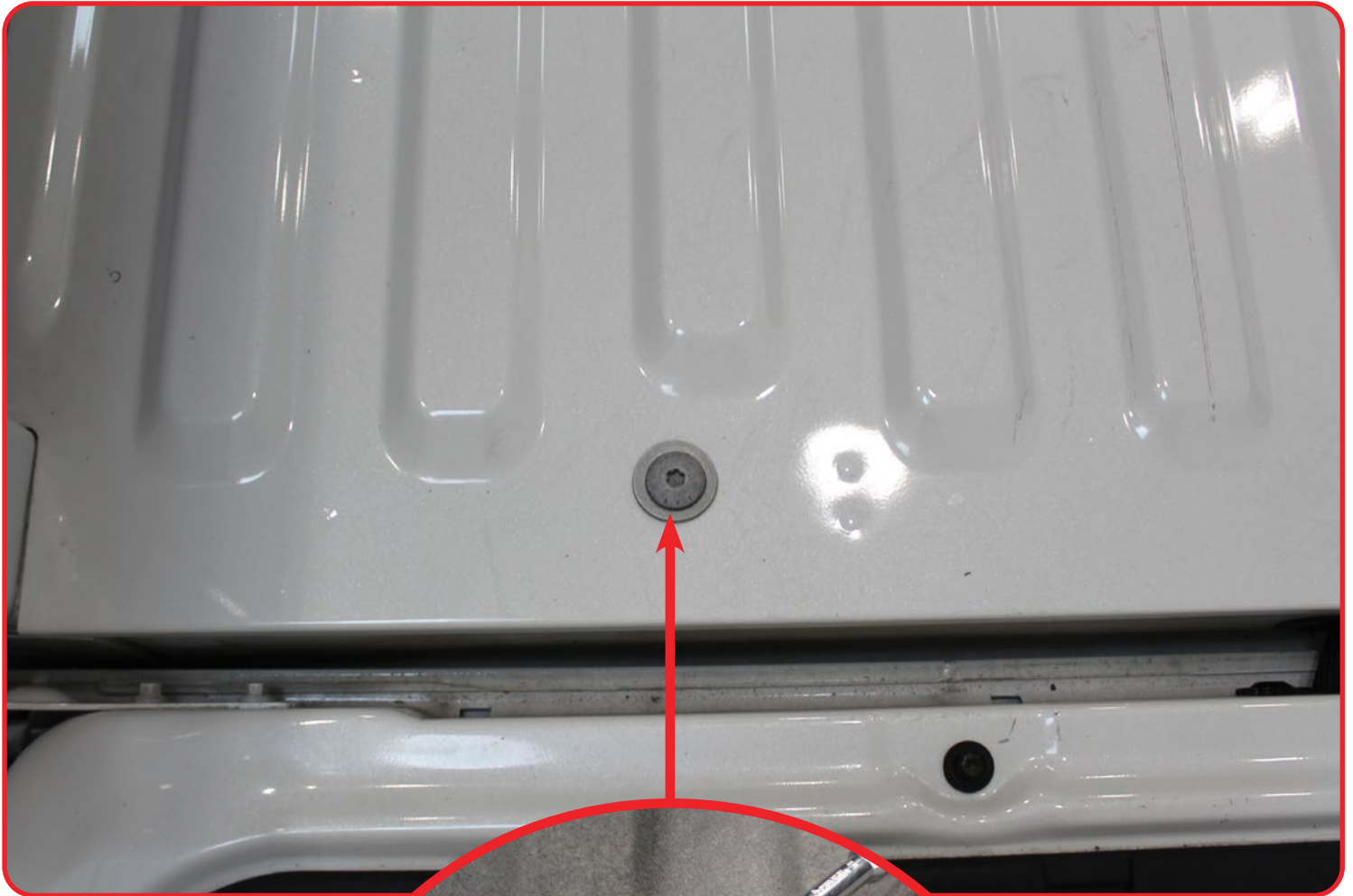

BED CHANNEL STIFFENER 23+ / FORD F-150

REMOVAL

□ STEP 2

Remove the tail light mounting bolts using a (8mm socket). Unplug the lights as shown below.

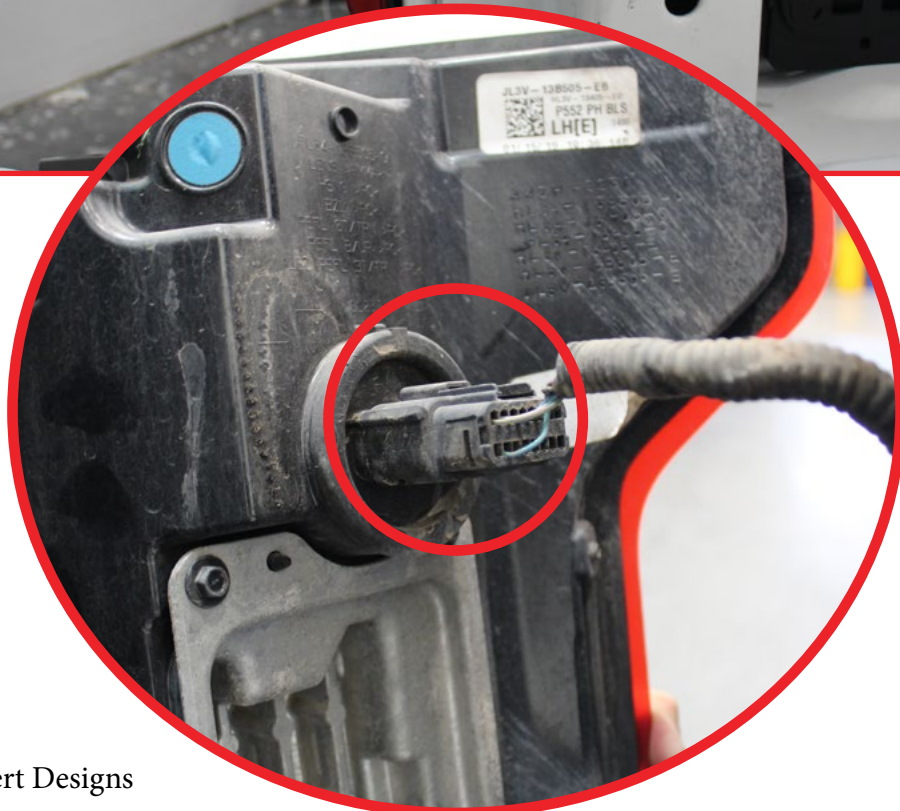
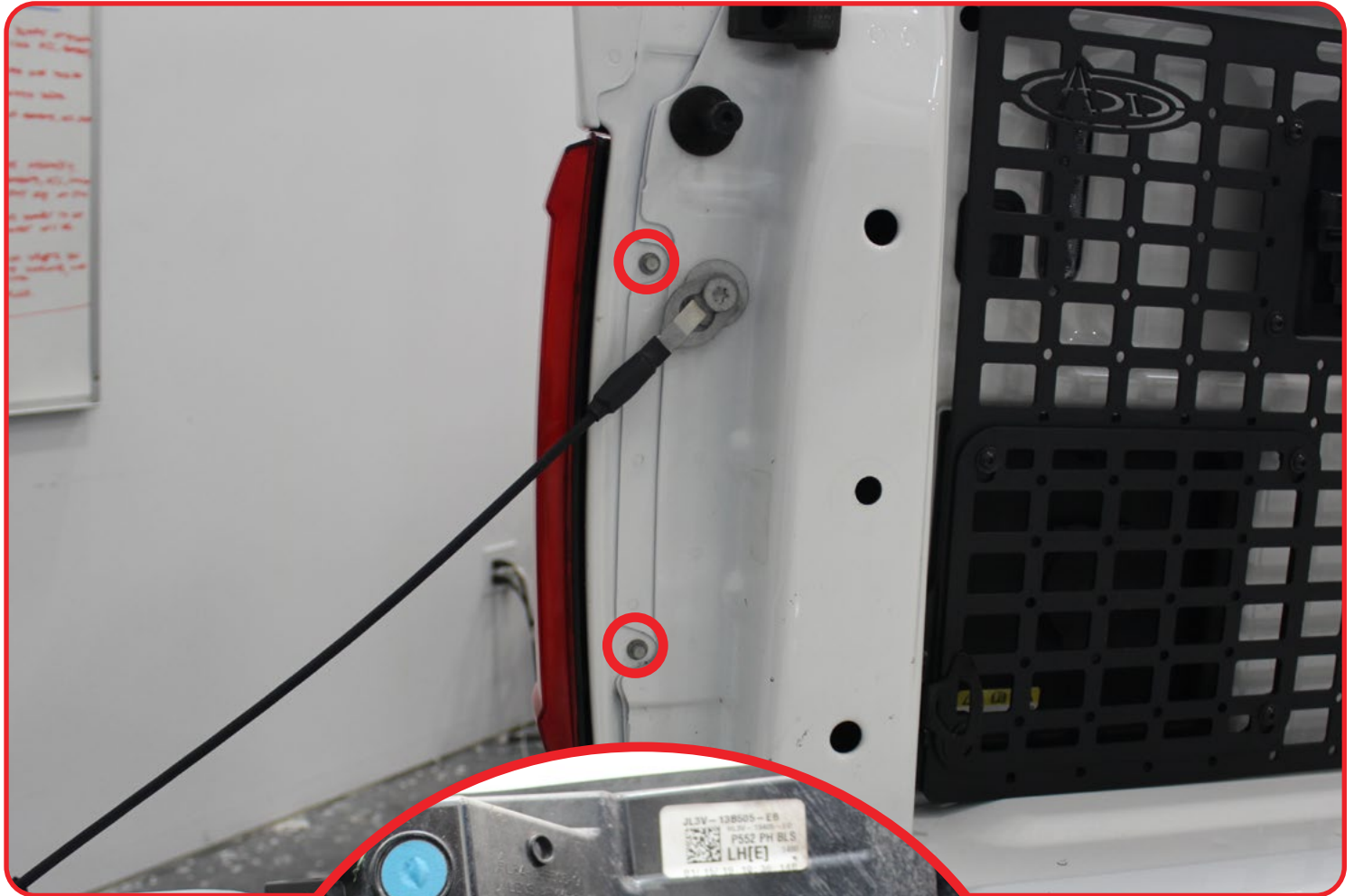

BED CHANNEL STIFFENER 23+/FORD F-150

REMOVAL

□ STEP 3

Install the bed channel stiffeners on the correct sides with the logos facing to the back of the truck. Install the OEM hardware removed from step 1 with a (T50 Torx).

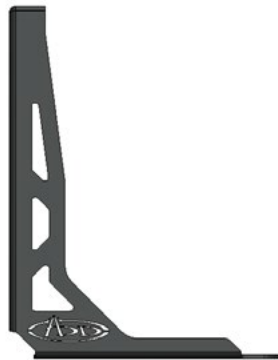

DRIVER



PASSENGER



BED CHANNEL STIFFENER 23+/FORD F-150

REMOVAL

□ STEP 4

Install the provided (**A**, **A1**, **A2**) hardware with the (**B**) washer on the inside of the tail light using a (5/16 allen) and a (3/4 wrench).

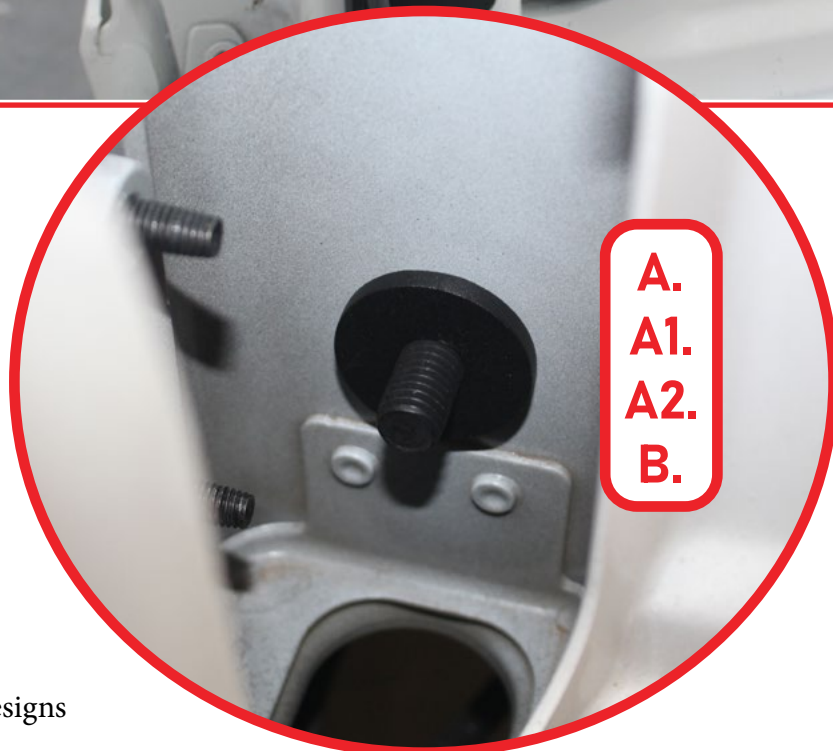

A.
A1.
A2.
B.

BED CHANNEL STIFFENER 23+ / FORD F-150

REMOVAL

□ STEP 5

Mark the hole located behind the ADD logo.



BED CHANNEL STIFFENER 23+/FORD F-150

REMOVAL

STEP 6

Remove the bed channel stiffener and drill the marked hole using a (9/16 drill bit).



BED CHANNEL STIFFENER

23+ / FORD F-150

REMOVAL

□ STEP 7

Repeat **step 3 & 4**, and install the provided (**A, A1, A2**) hardware through the bottom of the bed using a (5/16 allen) and a (3/4 wrench).

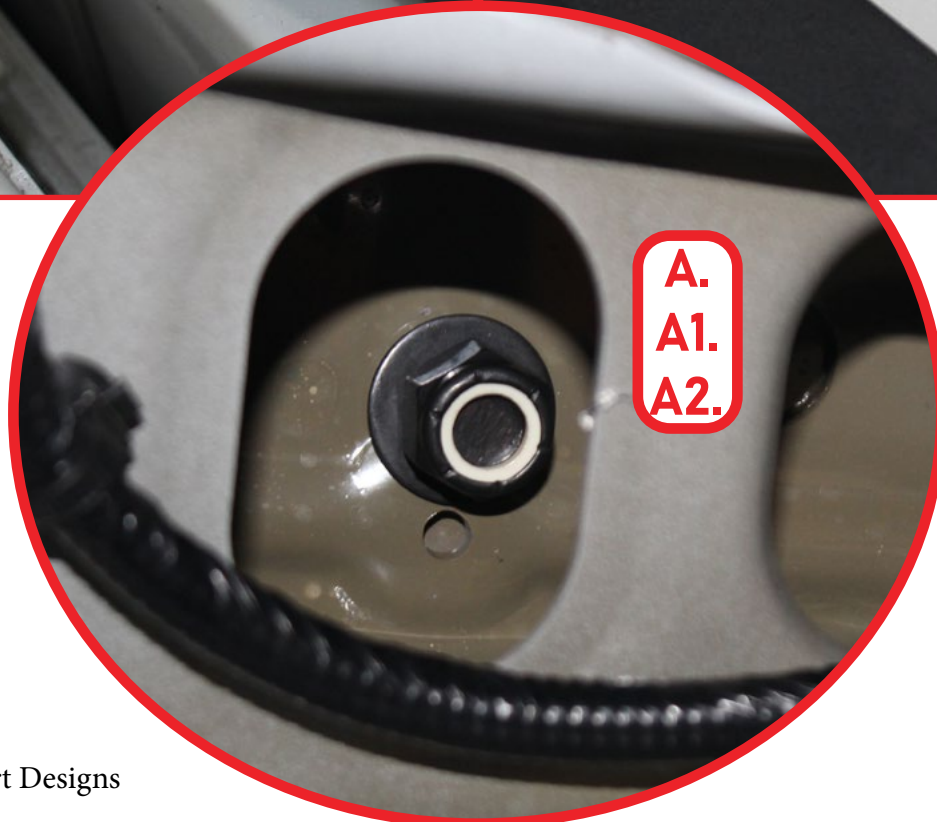

BED CHANNEL STIFFENER 23+/FORD F-150

INSTALL

□ STEP 8

Install the tail light mounting bolts using a (8mm socket). plug in the lights as shown below.

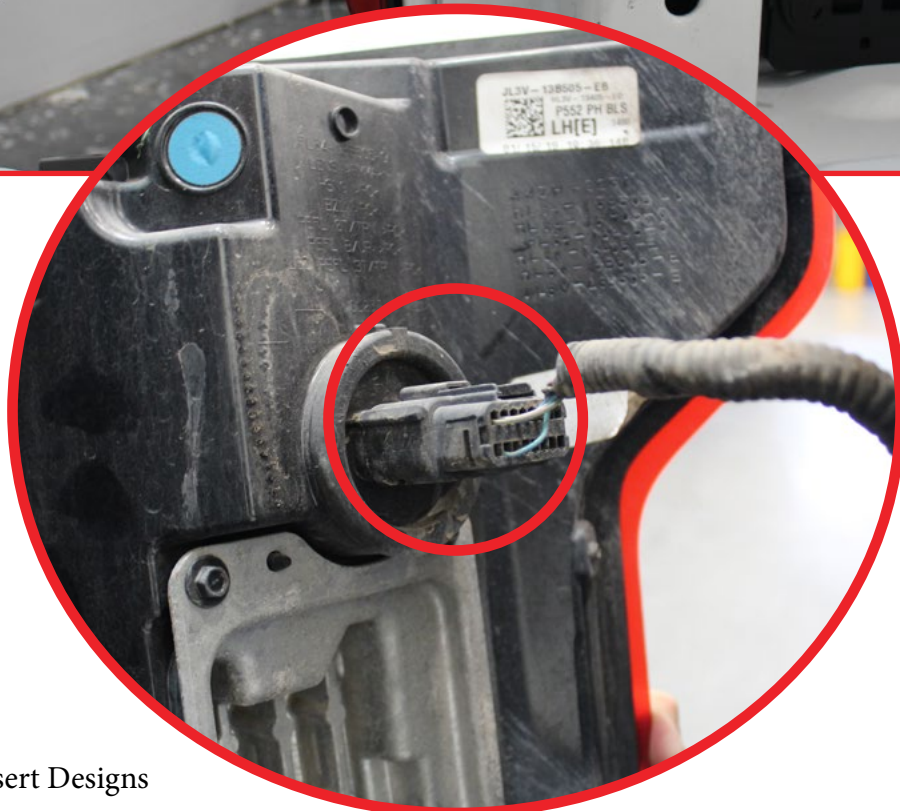
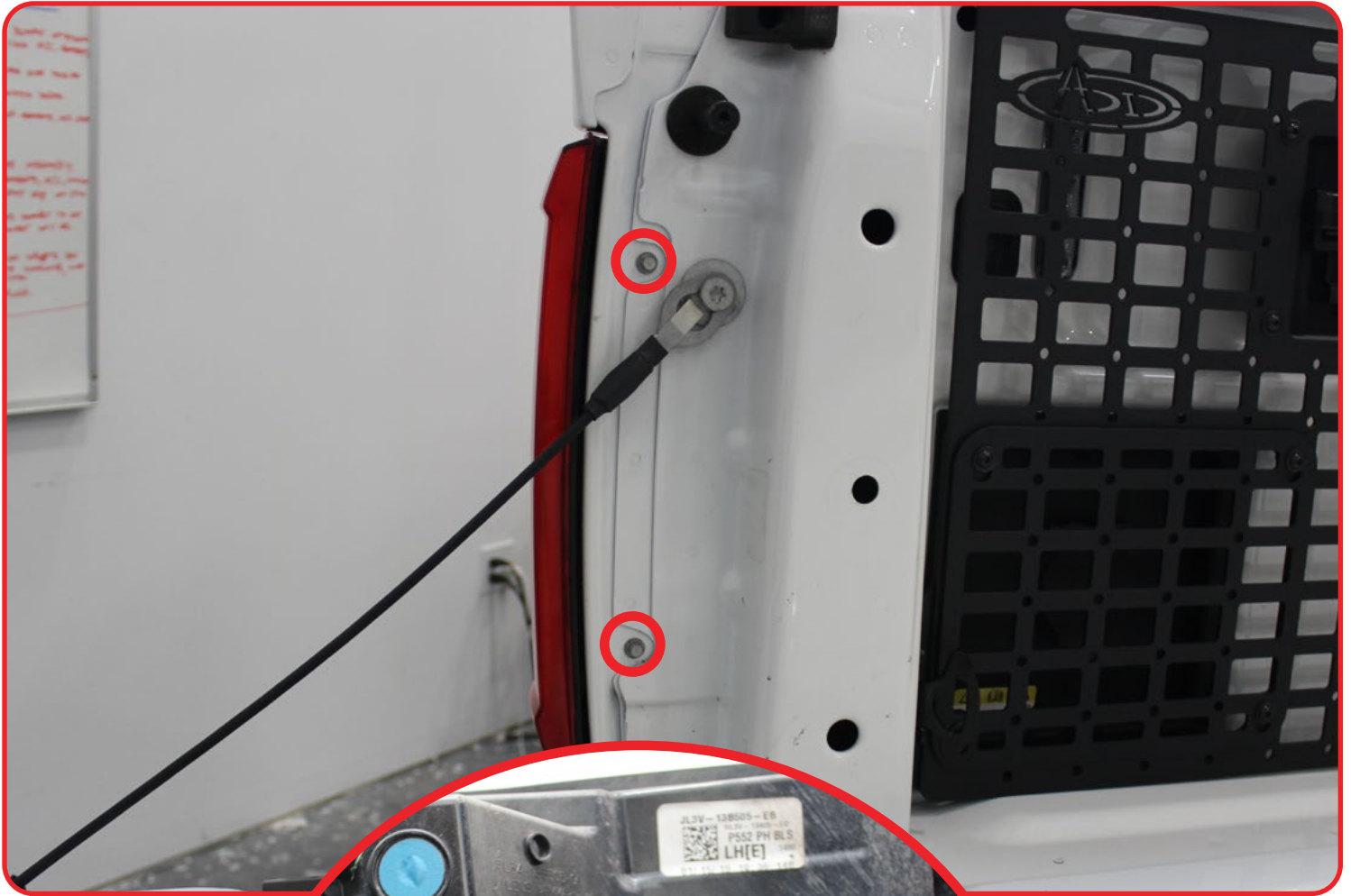

BED CHANNEL STIFFENER 23+ / FORD F-150

FINAL

STEP 9

Stand back and enjoy your new ADD Bed Channel Stiffener.

Check and re-tighten, if needed, all mounting bolts after 100 miles and periodically thereafter.



THIS PRODUCT IS PROTECTED BY ONE OR MORE U.S. PATENTS
WWW.ADDICTIVEDESERTDESIGNS.COM/PATENTS

FOR ADDITIONAL SUPPORT OR TECHNICAL QUESTIONS,
PLEASE CALL 480-671-0820 OR
EMAIL INFO@ADDICTIVEDESERTDESIGNS.COM